

## Assembly instructions for VarioShield<sup>PLUS</sup> lead lined plaster panels with overlap

These instructions show how you can construct a radiation-proof room with the VarioShield<sup>PLUS</sup> panels following a number of simple steps. These handy panels of VarioShield (600 mm x 1200 mm) are fitted with a lead overlap on one end and a thinned section on the other end. This makes the horizontal seams immediately radiation proof without any extra lead strip being required. This saves time and money. The panels can be mounted using a metal stud system.

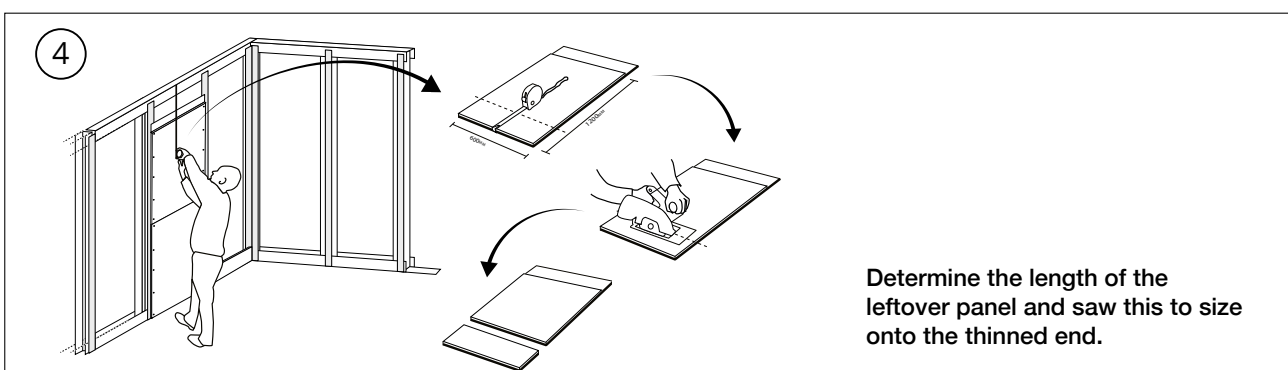

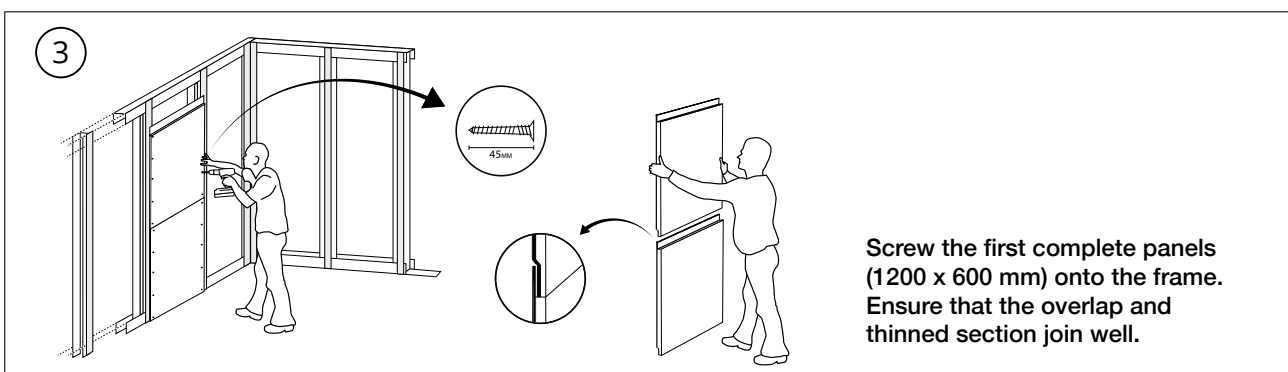
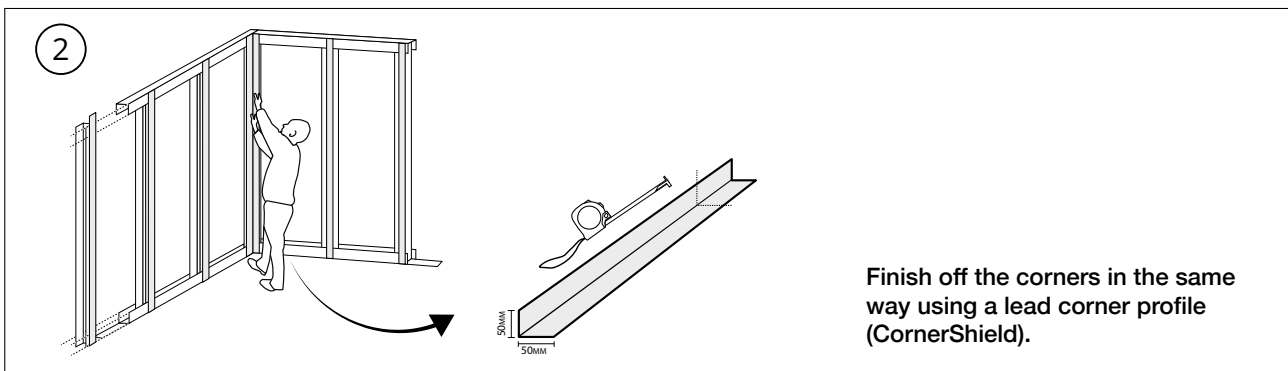
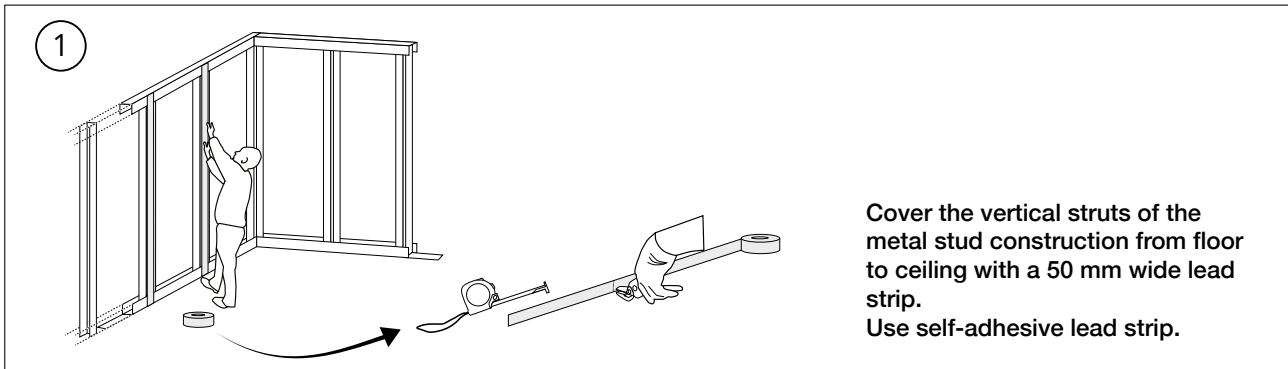
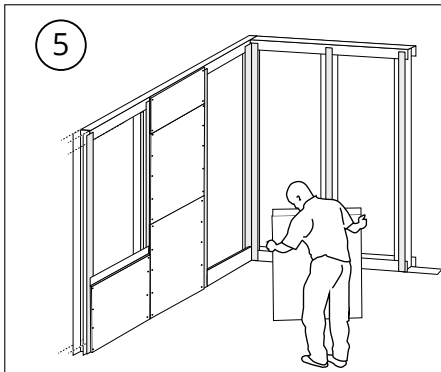

Start the second vertical strip from the bottom with the leftover piece of the first strip. Then do this in the same way for all the other strips.

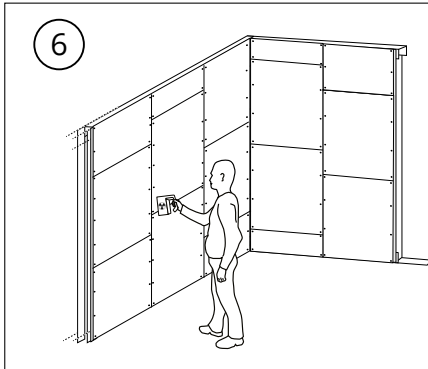

The room is now to be radiation proof (the system has been tested by Applus RTD).

#### The advantages of VarioShield<sup>Plus</sup> panels

- can make all areas radiation proof with a single standard size (600 x 1200 mm)
- sheets up to 2 mm lead less than 25 kg; sheets of 2.5 and 3 mm lead can be delivered on shorter panels
- quicker and easier to use
- easier to transport, less risk of damage
- shorter construction time
- minimal amount of waste
- saves costs and easy on the environment

#### Product description

VarioShield<sup>Plus</sup> (standard size): 12.5 x 600 x 1200 mm. Also available in other lengths.

Lead thicknesses: 1.0 mm – 1.5 mm – 2.0 mm – 2.5 mm – 3.0 mm

Applications: As radiation-proof wall or ceiling panel for the necessary protection of rooms where work is carried out using sources of radiation, such as in dentist and GP surgeries, hospitals, customs scanning units and laboratories.

#### Transport and storage

VarioShield<sup>Plus</sup> panels are supplied on returnable pallets. They should be stored in a dry space on a level and stable surface.

The overlap of a sheet may become deformed through a knock or the like. Any such deformity should be re-shaped before the sheet is used.

#### Assembly

Use VarioShield screws, sealing tape and filler as you would use when assembling standard plasterboard.

The thickness of the lead strip must correspond with the thickness of the lead on the panel used.

VarioShield lead lined plaster panels have been tested and approved by Applus RTD in standard setups.

